



Republic of the Philippines
Department of Environment and Natural Resources
Visayas Avenue, Diliman, 1100 Quezon City
Tel. Nos. (632) 8929-6626 to 29; (632) 8929-6633; to 35
Email: web@denr.gov.ph Website: www.denr.gov.ph

JUN 30 2023

DENR MEMORANDUM ORDER
No. 2023- 02

SUBJECT: GUIDELINES ON THE ESTABLISHMENT OF STORAGE FACILITIES FOR TURNED-OVER LOGS FROM TREE CUTTING PERMITS, AND SEIZED AND/OR CONFISCATED ILLEGAL FOREST PRODUCTS AND THE MACHINERY, EQUIPMENT, TOOLS, IMPLEMENTS, AND CONVEYANCES USED IN CONNECTION THEREWITH

Pursuant to Presidential Decree No. 705, as amended, or the "Revised Forestry Code of the Philippines", Executive Order No. 192, Series of 1987, entitled, "Providing for the Reorganization of the Department of Environment, Energy and Natural Resources, Renaming it as the Department of Environment and Natural Resources, and for Other Purposes", DENR Administrative Order (DAO) No. 2021-11, "Guidelines in the Processing and Issuance of Permits for the Cutting, Removal and Relocation of Naturally Growing Trees", DAO No. 1997-32, entitled, "1997 Rules for the Administrative Adjudication of Illegal Forest Products and the Machinery, Equipment, Tools and Conveyances Used in Connection Therewith", the following guidelines on the establishment of storage facilities for turned-over logs from tree cutting permits, and seized and/or confiscated illegal forest products, including machinery, equipment, tools, implements and conveyances used in connection therewith, are hereby promulgated.

I. DEFINITION OF TERMS

- a. Forest Products – refers to timber including lumber, pulpwood, firewood, bark, tree top, resin, gum, wood, oil, honey, beeswax, nipa, rattan, charcoal, or other forest growth, such as but not limited to grass, shrub, flowering plants in forestlands, and others.
- b. Illegal Forest Products – any forest products that are removed, cut, collected, processed, and/or transported: (i) without the requisite authorization or permit; (ii) with incomplete required supporting documents; (iii) with genuine authorizations or permits and/or supporting documentation that have an expired validity, have been canceled or that contain forged entries; or (iv) with spurious (fake) authorizations, permits, and/or supporting documentation.

- c. Storage Facilities – closed structure used for storing turned-over logs, seized and/or confiscated illegal forest products, and machinery, equipment, tools, implements and conveyances used in the possession, gathering, collecting, and/or processing of illegal forest products.
- d. Tree Cutting Permit (TCP) – a collective term for all the permits issued by the DENR for the cutting or removing of trees such as, but not limited to, Special Tree Cutting Permits, Special Private Land Timber Permits, Private Land Timber Permit, and Tree Cutting Permit.
- e. Turned-Over Logs – refers to logs derived through the cutting or removing of trees with the authority of a Tree Cutting Permit that are surrendered to the DENR for proper disposition.
- f. Conveyance – any mode or type or class of vehicle or craft or any other means used for transportation either on land, water, air, or any combination thereof, whether motorized or not, used for or in taking and/or maintaining temporary or permanent possession or control, gathering, collecting, processing, disposing of, or otherwise transporting, moving or transferring illegal forest products.

II. ESTABLISHMENT OF STORAGE FACILITIES

All Community Environment and Natural Resources Offices (CENROs) and Implementing Provincial Environment and Natural Resources Offices (Implementing PENROs), and Regional Offices, in the case of NCR, shall establish storage facilities for turned-over logs from Tree Cutting Permits (TCPs) and seized and/or confiscated illegal forest products, including machinery, equipment, tools, implements, and conveyances used in illegal logging activities.

A. SITE REQUIREMENTS

The CENROs and Implementing PENROs, or the Regional Office in the case of the National Capital Region (NCR) shall identify strategic sites that are adjacent to their offices or within their area of jurisdiction for the construction of storage facilities, provided that the storage facilities shall be established within public or patrimonial land of the state. Further, the storage facilities shall be constructed in areas that are not prone to flood and/or other factors that may cause or hasten the deterioration of the turned-over logs from TCPs and seized and/or confiscated illegal products and the machinery, equipment, tools, implements, and conveyances.

B. DESIGN AND LAY-OUT OF STORAGE FACILITIES

The storage facilities shall be in accordance with the design and lay-out provided in Annex 1 of this Order. The concerned CENROs or Implementing PENROs, and Regional Office in case of NCR, shall ensure that the storage facilities are installed with functional CCTV cameras for security purposes. The estimated establishment cost and standard material to be used for the construction of the storage facilities is provided under Annex 2 of this Order.

III. OPERATION, MAINTENANCE AND MANAGEMENT OF STORAGE FACILITIES

The CENROs or Implementing PENROs, or Regional Office, in the case of NCR, shall oversee the management and security of storage facilities and designate at least one (1) personnel who is holding a permanent/plantilla position capable of performing the following duties and responsibilities relevant to the operation, maintenance and management of the storage facilities:

- a) Oversee the daily operations and maintenance of storage facilities;
- b) Conduct inventory of items and evaluate the status of storage facilities; and
- c) Submit a report regarding the status of storage facilities and inventory of items to the CENROs or Implementing PENROs or Enforcement Division Chief in the case of NCR.

IV. MONITORING AND REPORTING

The CENROs or Implementing PENROs, or Enforcement Division in the case of NCR, shall prepare a report using the standard prescribed reporting format provided under Annex 3 of this Order, to the concerned Regional Office, copy furnished the PENRO, PENRO Accountant and the PENRO Auditor, containing the following information:

1. Completion of Construction Report - contains a description of the storage facilities constructed, including the location and date of construction among others, to be submitted thirty (30) calendar days upon completion of the storage facilities.
2. Quarterly status report of storage facilities – provides a summary of the items currently stored in the storage facilities, including the condition of the storage facilities.
3. Quarterly inventory of items – a complete list of all turned-over logs from TCPs seized and/or confiscated illegal forest products, and the machinery,

equipment, tools, implements, and conveyances stored in the storage facility, with description of each item, date of seizure and/or confiscation, current condition, estimated market value of the items, date of disposition and mode of disposition.

The Regional Offices shall use the Electronic Filing and Monitoring System (e-FMS) for illegal logging cases as the repository of reports on apprehension, seizure and confiscation of undocumented forest products, including the machinery, equipment, tools, implements, and conveyances used in connection therewith. The Regional Offices shall also maintain an online database on the storage facilities, using the prescribed electronic spreadsheet format provided under Annex 4 of this Order. The online database shall be a consolidation of the completion of construction report, operational report on the quarterly status report and quarterly inventory of items report submitted by the CENROs or Implementing PENROs, or Enforcement Division in the case of NCR to the Regional Office. Finally, the Regional Office shall submit an annual report regarding the storage facilities in the succeeding month of the following year, using the format provided under Annex 5 of this Order, to the Office of the Undersecretary for Field Operations, copy furnished to the Director of the Forest Management Bureau.

V. FUNDING

The CENROs and Implementing PENROs, or Regional Office, in case of NCR, shall allocate funds for the construction of the storage facilities. The amount allocated for the construction of the storage facilities shall be reviewed and adjusted every five years or as deemed necessary due to extraordinary circumstances.

Further, concerned offices shall allocate sufficient amount from their respective annual budget for the management and maintenance of the constructed storage facilities as deemed necessary; provided that the concerned Office shall submit a detailed report on the status of the storage facilities indicating the need for maintenance to the Office of the Undersecretary for Field Operations copy furnished the Forest Management Bureau.

This Order shall take effect immediately.

MARIA ANTONIA YULO LOYZAGA
Secretary



Annex 1. Design and Layout for the Storage Facilities

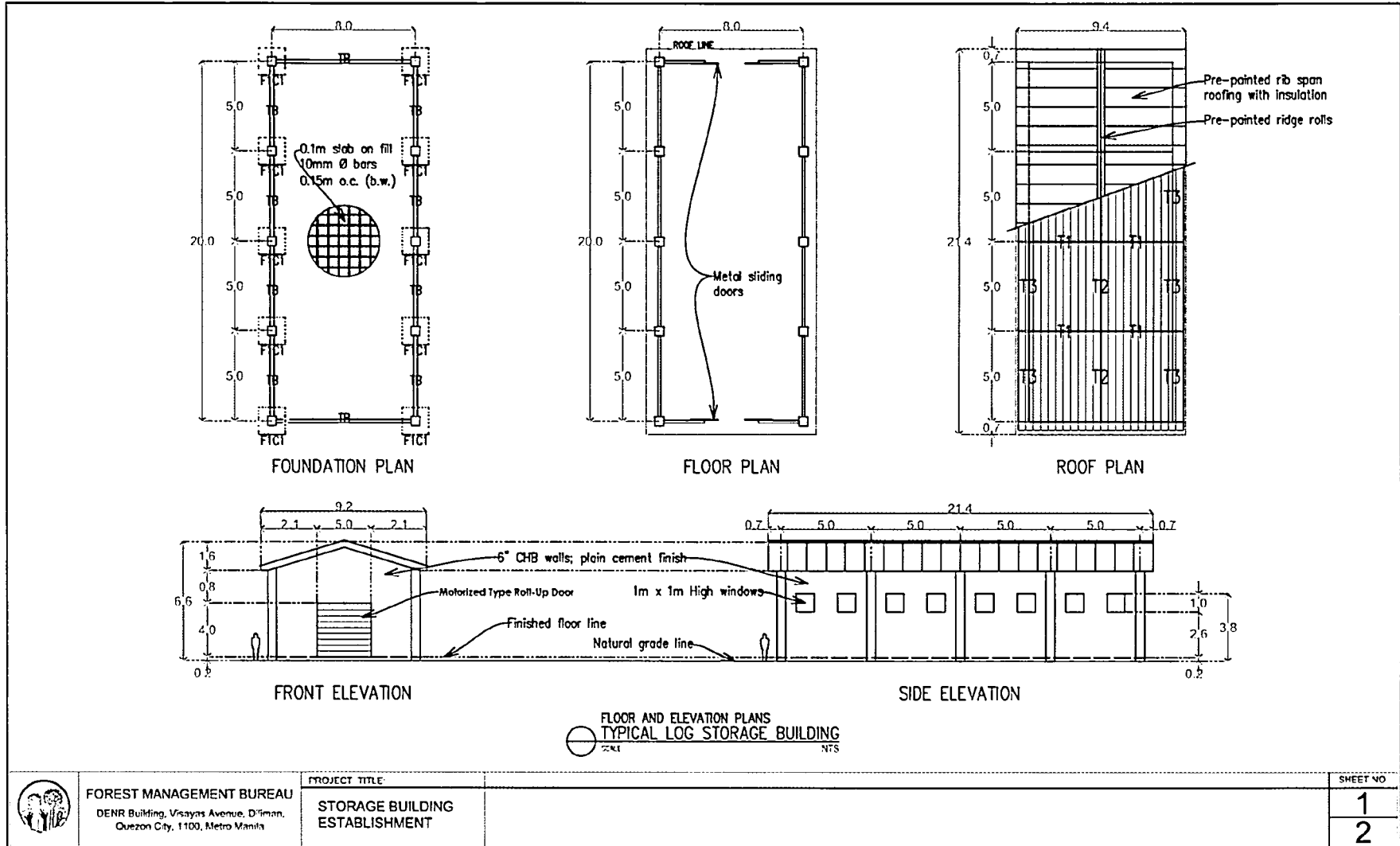

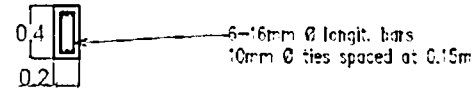

"FTB"

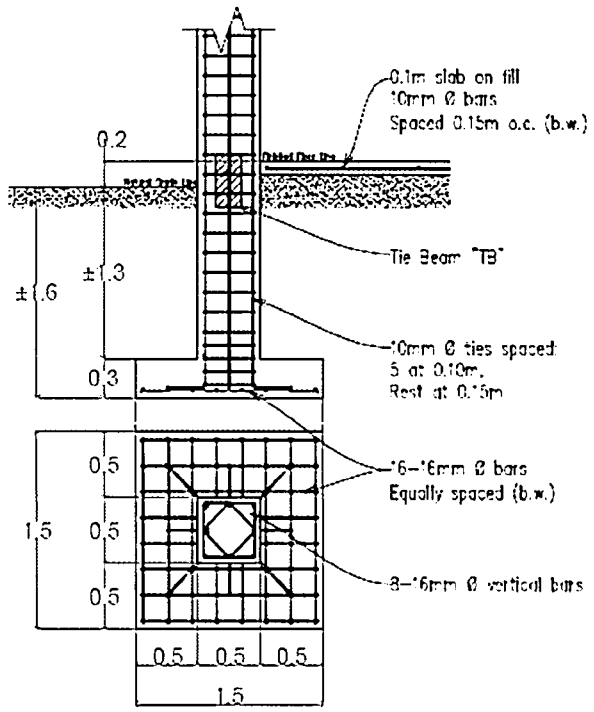

"F101"

SECTION DETAIL
COLUMNS AND BEAMS

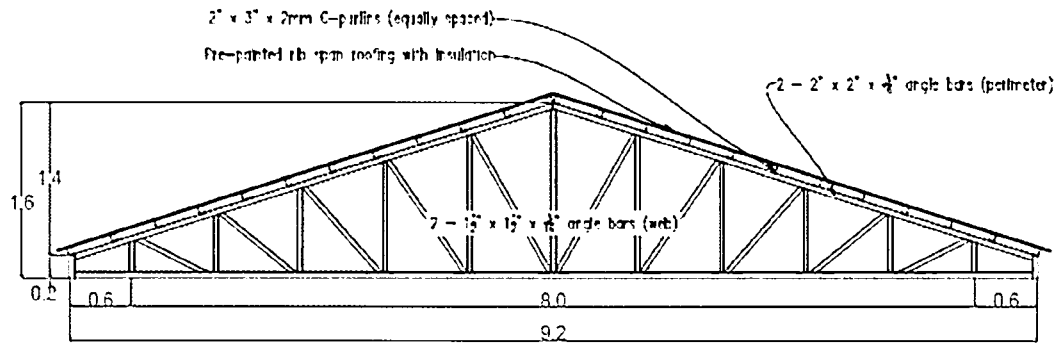

"T1"

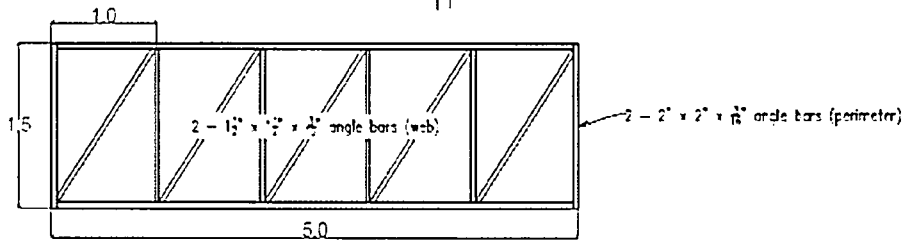

"T2"

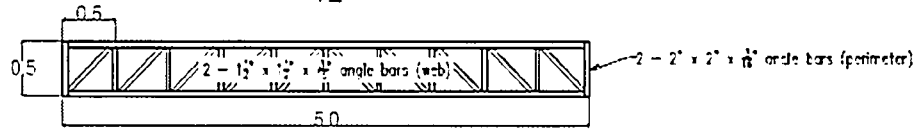

"T3"

SECTION DETAIL
ROOFING AND TRUSSES



FOREST MANAGEMENT BUREAU
DENR Building, Vilayas Avenue, Diliman,
Quezon City, 1100, Metro Manila

PROJECT TITLE
STORAGE BUILDING
ESTABLISHMENT

SHEET NO
2
2

Annex 2. Detailed Costs and Standard Material for the Storage Facilities

PROJECT: PROPOSED TYPICAL LOG STORAGE BUILDING					
SUBJECT: BILL OF MATERIALS AND COST ESTIMATES					
DATE: As of April 24, 2023					
ITEM	DESCRIPTION	QTY	UNIT	UNIT COST	AMOUNT (PHP)
I.	Concreting Works (Columns, Walls, Foundations, Slabs)				
	6" CHB	2960	pcs	20.00	59,200.00
	Cement	619	bags	250.00	154,750.00
	Sand	47	cu.m	1,500.00	70,500.00
	Gravel	25	cu.m	2,100.00	52,500.00
	10mm Rebar (6m)	564	pcs	150.00	87,600.00
	16mm Rebar (6m)	190	pcs	310.00	58,900.00
	GI Tie Wires #16	49	kg	85.00	4,165.00
	Paint Works (materials)	474	sq.m	80.00	37,920.00
	Epoxy Floor Coating	160	sq.m	180.00	28,800.00
	Form Works (materials)	1	lot	25,000.00	25,000.00
	Sub-total				579,335.00
II	Steel Works (Roofing)				
	2" x 2' x 3/16" Angle Bar (6m)	79	pcs	1,200.00	94,800.00
	1.5" x 1.5' x 3/16" Angle Bar (6m)	89	pcs	620.00	55,180.00
	Steel Plate (3/16")	6	sq.m	2,100.00	12,600.00
	2" x 3" x 2mm C-Purlin (6m)	77	pcs	500.00	38,500.00
	Tekscrews	1520	pcs	2.00	3,040.00
	Rib-type Long Span (Colored). G-24 (0.6mm thick)	192	sq.m	650.00	124,800.00
	Insulation Foam Double Sided (10mm thick)	192	sq.m	115.00	22,080.00
	Pre-painted Ridge Roll (8")	10	pcs	150.00	1,500.00
	Consumables (weld rods, etc.)	1	lot	15,000.00	15,000.00
	Sub-total				367,500.00
III	Electrical				
	Outlet (2 geng universal)	10	pcs	110.00	1,100.00
	Industrial Ceiling Fan	3	pcs	5,500.00	16,500.00
	General Electrical (Wiring, Breakers, Panels, Lights, etc.)	1	lot	30,000.00	30,000.00
	Consumables	1	lot	15,000.00	15,000.00
	Sub-total				62,600.00
IV	Finishing (Labor and Materials)				
	Motorized Type Roll Up Door	2	sets	58,805.00	117,610.00
	Awning Type Steel Casement Window (1m x 1m)	16	sets	1,920.00	30,720.00
	Door and Window Consumables	1	lot	10,000.00	10,000.00
	Sub-total				158,330.00
V	Summary				
	Total Materials Cost				1,167,765.00
	Labor Cost (30%)				350,329.50
	Excavation Works	35	cu.m	400.00	14,400.00
	Total Direct Cost				1,532,494.50
	Overhead, Contingencies, and Miscellaneous				153,249.45
	Contractor's Profit				99,970.34
	Total Indirect Cost				253,219.79
	VAT (12%DC and IC)				214,285.71
	TOTAL PROJECT COST				2,000,000.00

Annex 3. Format of Reporting for the Status Report of Storage Facilities and Inventory of Items to be submitted by CENRO or Implementing PENROs, or Enforcement Division in case of NCR to the Regional Office

**DENR CENRO/Implementing PENRO (Name of Office)
(Office Address)**

Table 1. Completion of Construction Report

Name of Office	Location of Storage Facility (Barangay, Municipality, Province)	Date of Construction (Month, Day, Year)	Storage Facility Code
CENRO Dupax	Inaban, Dupax del Norte, Nueva Vizcaya	September 1, 2023	PSGC

Table 2. Quarterly Status Report of Storage Facilities

Storage Facility Code (SFC)	Total Volume of Seized Forest Products (bd. ft)	Total Volume of Confiscated Forest Products (bd. ft)	Total No. of Seized Machinery, Equipment, tools and conveyances Stored (no)	Total No. of Confiscated Machinery, Equipment, tools and conveyances Stored (no)	Total Market Value of Items (Php)	Status of Storage Facility (serviceable/non-serviceable)
PSGC	20	10	2	5	1,500,000	serviceable
Grand Total						

Table 3. Quarterly Inventory of Items Stored in the Storage Facility (SFC)

Item No. (Date Stored-xx)	Item (Logs/Lumber, Charcoal, Chainsaw, etc)	Location of Apprehension (Barangay, Municipality, Province)	Date Stored in the Facility	Type of Items (FP, METI)	Status of Items Stored (Seized, Confiscated)	Volume of Forest Products Stored (bd. ft.)	No. of Machinery, Equipment, tools and conveyance Stored (no)	Market Value of Items	Date of Disposition	Mode of Disposition (Donation, Auction, Others)
10012023-01	Logs	Inaban, Dupax del Norte, Nueva Vizcaya	October 1, 2023	FP	Confiscated	20	-	3,000,000.00	December 1, 2023	Donation
10052023-02	Charcoal	Belense, Dupax del Norte, Nueva Vizcaya	October 5, 2023	FP	Seized	25	-	30,000.00	December 1, 2023	Donation
01202024-03	Chainsaw	Inaban, Dupax del Norte, Nueva Vizcaya	January 20, 2024	METI	Seized		2	50,000.00	March 1, 2024	Auction
Grand Total										

Prepared by:

Reviewed by:

Approved by:

Enforcement Section/Unit Personnel

Chief, Enforcement Section/Unit

CENRO/Implementing PENRO

Annex 4. Format of Online Database to be maintained by the Regional Office

**DENR Regional Office (Name of Office)
(Office Address)**

Table 1. Status Report of Storage Facilities within Region ____

Region	PENRO	CENRO	Location of Storage Facility (Barangay, Municipality, Province)	Date of Construction (Month, Day, Year)	Total Volume of Seized Forest Products Stored (bd. ft)	Total Volume of Confiscated Forest Products Stored (bd. ft)	Total No. of Seized Machinery, Equipment, tools and conveyance Stored (no)	Total No. of Confiscated Machinery, Equipment, tools and conveyance Stored (no)	Total Market Value of Items (Php)	Status of Storage Facility (serviceable/ non-serviceable)
II	Nueva Vizcaya	CENRO Dupax	Inaban, Dupax del Norte, Nueva Vizcaya	September 1, 2023	20	10	2	5	3,000,000.00	Serviceable
II	Nueva Vizcaya	CENRO Dupax	Belense, Dupax del Norte, Nueva Vizcaya							
II	Nueva Vizcaya	CENRO Dupax	Inaban, Dupax del Norte, Nueva Vizcaya							
II	Nueva Vizcaya	CENRO Aritao	Banganan, Aritao, Nueva Vizcaya							
Grand Total										-

Table 2. Inventory of Items stored in the Storage Facilities within DENR Region ____

Region	PENRO	CENRO	Item No. (Date Stored-d-xxx)	Item (Logs/ Lumber, Charcoal, Chainsaw, etc)	Location of Apprehension (Barangay, Municipality, Province)	Date Stored in the Facility	Type of Items (FP, METI)	Status of Items Stored (Seized, Confiscated)	Volume of Forest Products Stored (bd. Ft.)	No. of Machinery, Equipment, tools and conveyance Stored (no)	Market Value of Items (Php)	Date of Disposition	Mode of Disposition (Donation, Auction, Others)
II	Nueva Vizcaya	CENRO Dupax	100120 23-001	Logs	Inaban, Dupax del Norte, Nueva Vizcaya	October 1, 2023	FP	Confiscated	20	-	3,000,000.00	December 1, 2023	Donation
II	Nueva Vizcaya	CENRO Dupax	100520 23-002	Charcoal	Belense, Dupax del Norte, Nueva Vizcaya	October 5, 2023	FP	Seized	.25	-	30,000.00	December 1, 2023	Donation
II	Nueva Vizcaya	CENRO Dupax	012020 24-003	Chainsaw	Inaban, Dupax del Norte, Nueva Vizcaya	January 20, 2024	METI	Seized		2	50,000.00	March 1, 2024	Auction
II	Nueva Vizcaya	CENRO Aritao	021520 24-001	Chainsaw	Banganan, Aritao, Nueva Vizcaya	February 15, 2024	METI	Confiscated		3	75,000.00		
Grand Total													

Annex 5. Format of Reporting for the Status of Storage Facilities to be submitted annually by the Regional Office to the OUFO, cc FMB

**DENR Regional Office (Name of Office)
(Office Address)**

Table 1. Status Report of Storage Facilities constructed within DENR Region _

Region	PENRO	CENRO	Location of Storage Facility (Barangay, Municipality, Province)	Date of Construction (Month, Day, Year)	Total Volume of Seized Forest Products Stored (bd. ft)	Total Volume of Confiscated Forest Products Stored (bd. ft)	Total No. of Seized Machinery, Equipment, tools and conveyances Stored (no)	Total No. of Confiscated Machinery, Equipment, tools and conveyances Stored (no)	Status of Storage Facility (serviceable/non-serviceable)
<i>II</i>	<i>Nueva Vizcaya</i>	<i>CENRO Dupax</i>	<i>Inaban, Dupax del Norte, Nueva Vizcaya</i>	<i>September 1, 2023</i>	<i>.25</i>	<i>20</i>	<i>2</i>	<i>-</i>	<i>Serviceable</i>
<i>II</i>	<i>Nueva Vizcaya</i>	<i>CENRO Aritao</i>	<i>Banganan, Aritao, Nueva Vizcaya</i>	<i>September 24, 2023</i>	<i>-</i>	<i>-</i>	<i>-</i>	<i>3</i>	<i>Serviceable</i>
Grand Total									-

Prepared by:

Approved by:

Chief, Enforcement Division

Regional Executive Director